

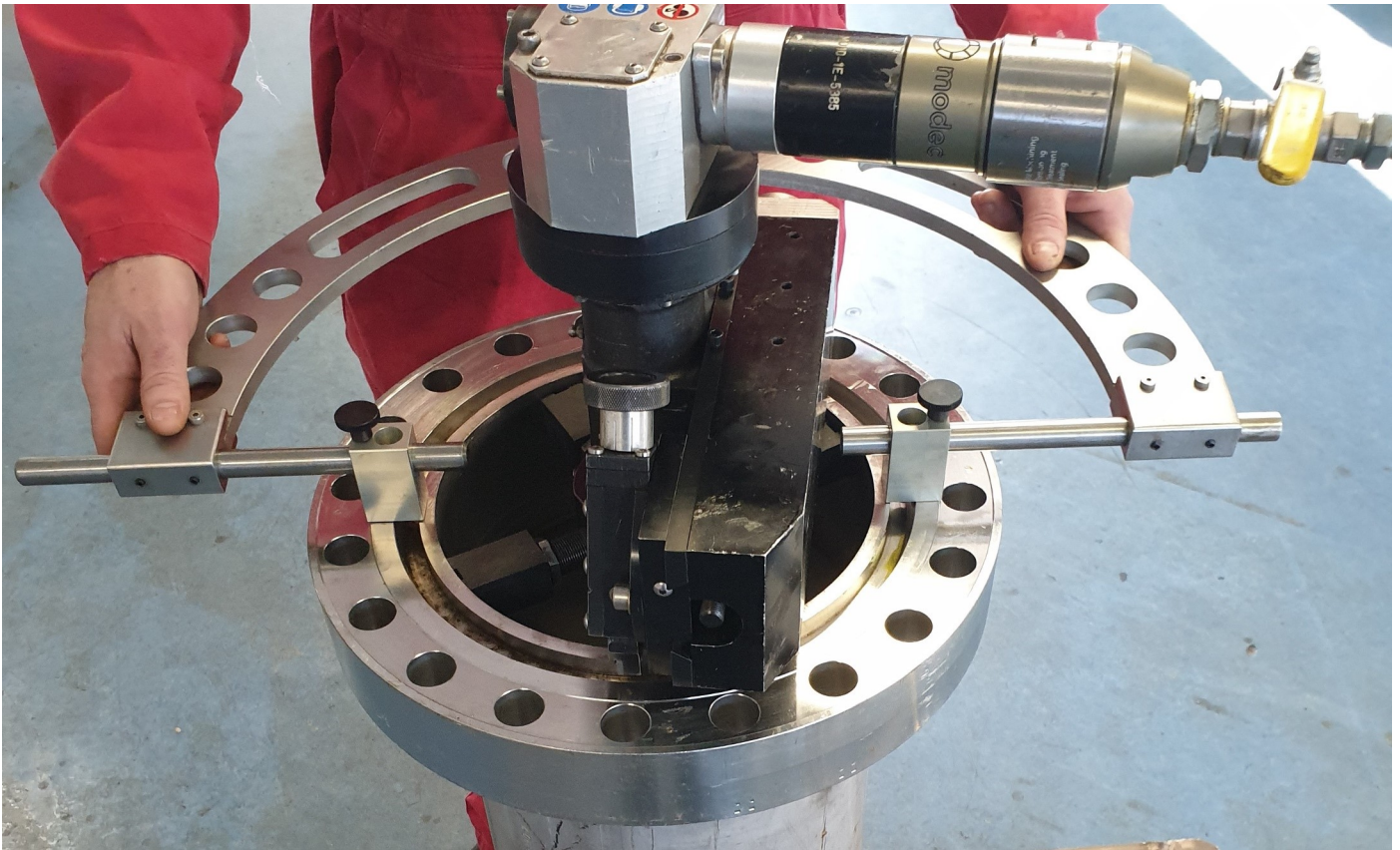

normaco

Portable Machining Tools

Measuring Arcs for RTJ Flanges



- Ⓢ Quick Measuring of RTJ Flange Grooves
- Ⓢ No Calibration Needed Prior Use
- Ⓢ Light and Comfortable to Handle
- Ⓢ Durable Construction



Measuring Arc

The measuring arc is used with the V-groove kit to measure the groove dimensions on flanges. The Arc offers the additional benefit of being able to measure the groove diameter, while the ID mounted flange facer is mounted on the flange.

The arc offers wide measuring capability, up to 1196mm in diameter.

Measuring Arc 500 is the original model manufactured by Normaco featuring large arc.

Measuring Arc SQ is an improved model with new square shape and smaller footprint to enable easier operation on site and smaller space requirement during transport and storage.

Technical Data:	Measuring Arc SQ	Measuring Arc 500
Max measuring \varnothing	1156 mm	1196 mm
Min measuring \varnothing	24 mm	24 mm
Weight in use	2 kg	2 kg
Shipping dims.	65 x 25 x 4cm	65 x 39 x 4cm
Part Number	301796	301776

Technical Details

Measuring Arc 500

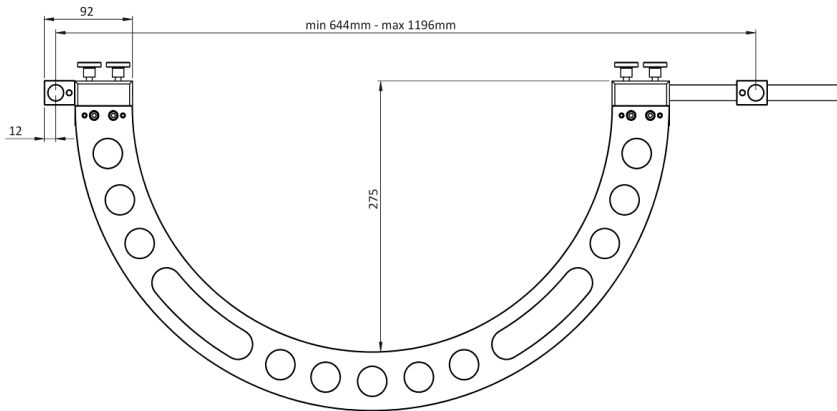

Arc configuration with blocks mounted outwards.

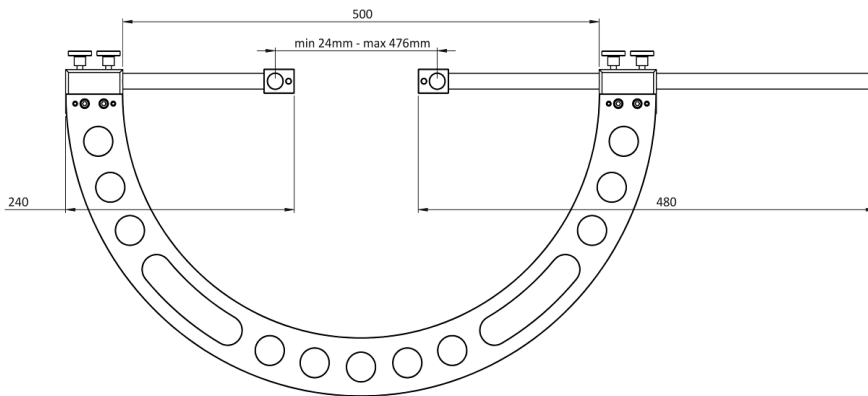

Arc configuration with blocks mounted inwards.

Measuring Arc SQ

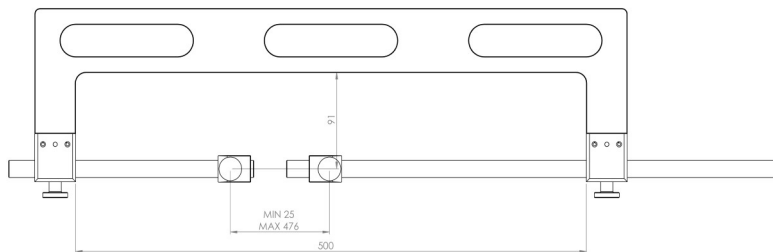

Arc configuration with blocks mounted outwards.

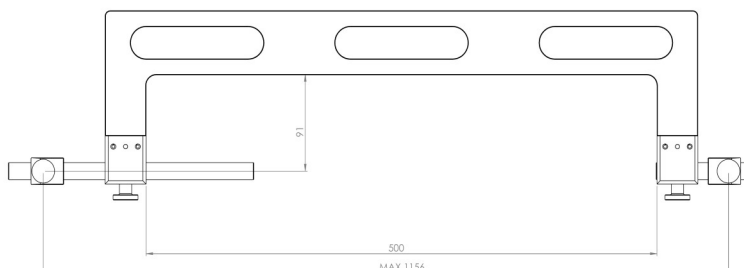

Arc configuration with blocks mounted inwards.