



- ⊗ Easily portable
- ⊗ Cold work - no sparking
- ⊗ Durable guide rails – no moving parts
- ⊗ Air cooling for mill cutter.
- ⊗ Flexible mounting options

The Milling Machine has a light weight aluminium construction and it is equipped with high quality linear guideways and ball screws.

It is equipped with high quality air motors that power the machine reliably.

Machine can be delivered in different bed lengths and either with manual or pneumatic auto feed.

Normaco Lightweight Milling Machine is portable and pneumatically powered 2-axis milling machine.

It has been especially developed for applications where the extremely light weight of the machine is critical. For example for work in areas where the equipment must be carried by hand or rope access work.

The Portable Milling Machine is mounted directly to the work piece by bolting, welding or using a magnet base. It can also be secured with vacuum pads that allow the mounting to an non-ferrous material and without damaging the mounting area.

Pneumatic motor and low milling cutter speed make it possible to use the portable milling machine in areas where cold work is a requirement.



**normaco**  
Portable Machining Tools

## 2-Axis LW Portable Milling Machine

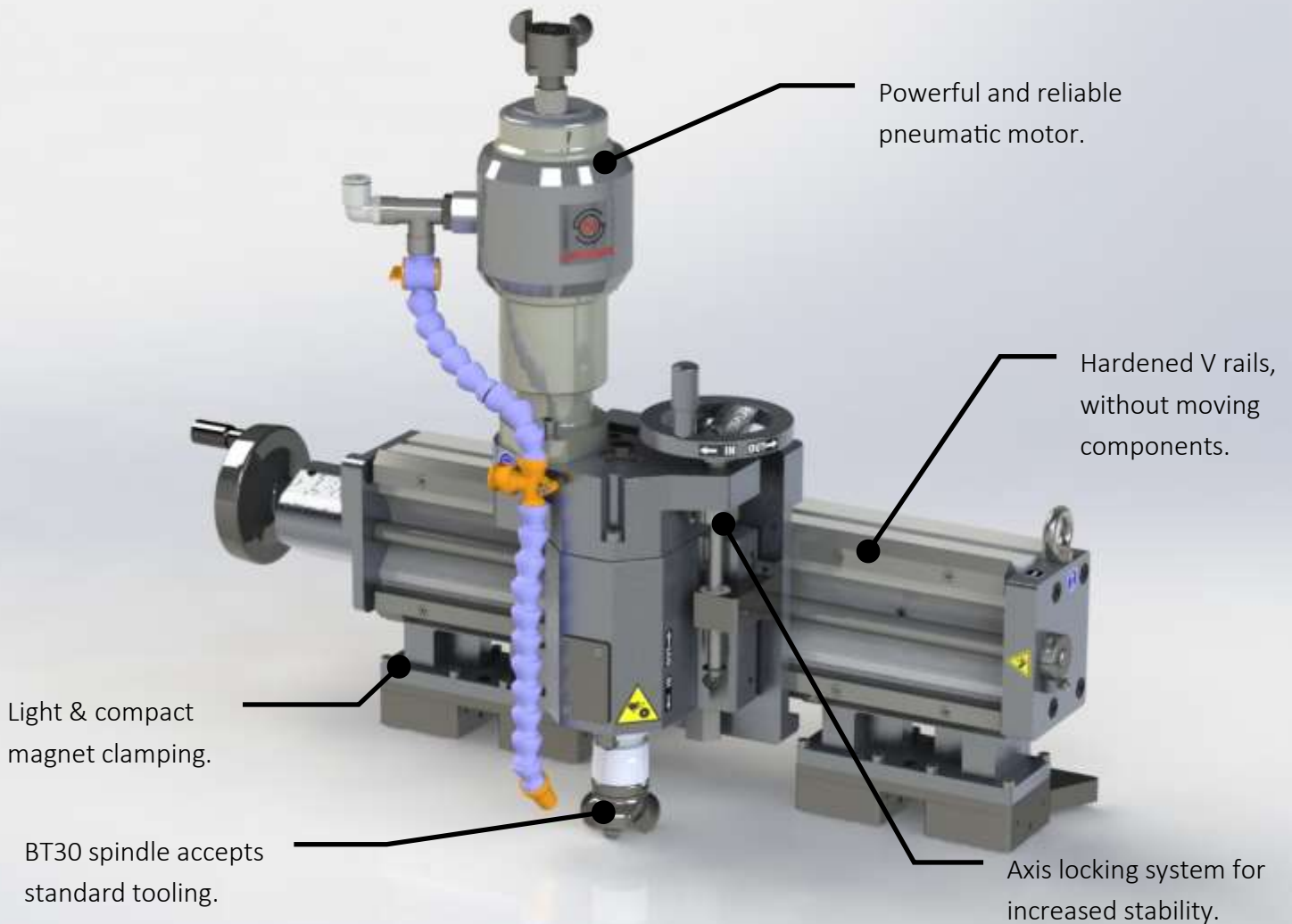

<b>Mounting Options:</b>
<b>Standard:</b>
Welded or bolted base
<b>Optional;</b>
Magnet base 300kg
Vacuum clamping



# 2-Axis LW Portable Milling Machine

### Machine delivery includes

- Milling machine with Spindle Motor
- Transport and storage box
- Analogue indicator for depth measurement
- DIN standard lifting bolts (certified optional)
- Set of hand tools
- CE certification and operation manual



### Technical Data

Travel	X-travel: *
	425 mm /
	1000 mm /
Feed	1500 mm
	Z-travel: 80 mm
	X-axis: Manual /
Spindle	Auto (optional)
	Z-axis: Manual
	Motor:
Spindle	Pneumatic 3kW /
	Right angle 2.5kW
	(optional)
	Depth measurement
	with analogue read-out
	Spindle BT30
850rpm	
Air Cooling	

X Axis Travel	Operational weight:	Shipping weight:
425mm	52 kg	90 kg
1000mm	65kg	120 kg
1500mm	77kg	150 kg

\* length of continuous travel depends on mounting options.

Spindle air motor must be used with Normaco Air safety device to maintain air motor warranty and CE-compliance.

All information contained in this document is subject to change without prior notice



## Machine dimensions with manual feed

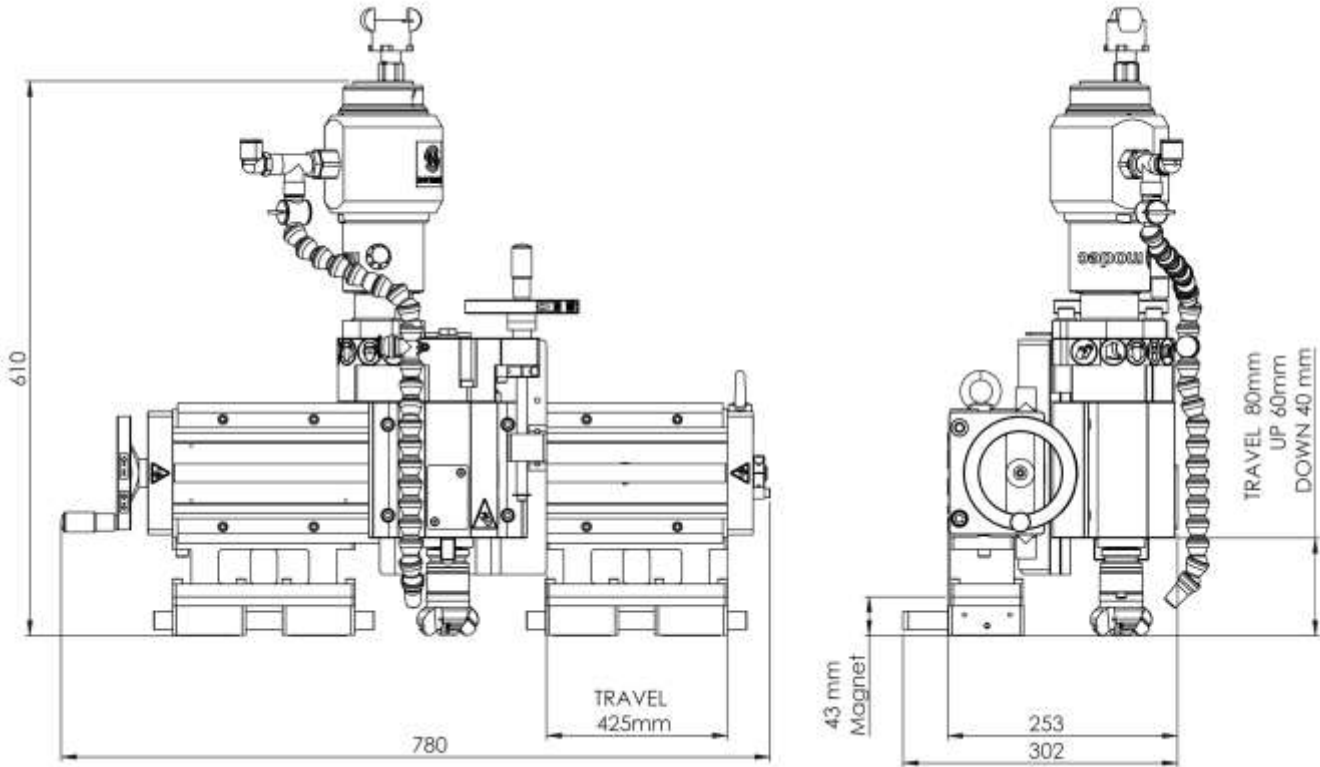

## Machine dimensions with auto feed

